

	GLOBAL STANDARD	Page 1 of 36
	UP - Box for outdoor installations	<b>GSTR001/3</b> Rev. 01

## UP - Box for outdoor installations

This document describes the box for outdoor installations of the UP, the Remote Terminal Unit for telecontrol and supervision of Medium Voltage distribution network; it provides functional and construction requirements for the supply.

Countries' I&N – NTI	Elaborated by	Verified by	Approved by
Argentina			Mario Colonnello
Brazil			Victor Manuel Galvão Macedo Costa
Chile			Hans Christian Rother Salazar
Colombia			Cesar Augusto Rincon Alvarez
Iberia			Maria Avery Fernandez
Italy			Gianluca Sapienza
Peru			Roberto Leonidas Sanchez Vargas
Romania			Ivano Bonfanti

	Revision	Elaborated by	Collaborations	Verified by	Approved by
Global I&N – NTI/SGS	01	Giorgio Scrosati	Erika Lino	Erika Lino	Giorgio Di Lembo
Global I&N – NTI/SGS	00	Giorgio Di Lembo Lilia Consiglio	Countries' I&N – NT	Maria Avery José Luis Calero	Giorgio Di Lembo

This document is intellectual property of Enel Spa; reproduction or distribution of its contents in any way or by any means whatsoever is subject to the prior approval of the above mentioned company which will safeguard its rights under the civil and penal codes.

It is for internal Use. Each Country can provide a translation in local language but the official reference document is this GS English version.

Revision	Data	List of modifications
00	02.11.2015	First version
01	08.08.2017	Chapter 10 review, including in the supply conditions: TCA documents, manuals delivery and safety information on plate; Chapter 11 added, on safety requirements; Other minor fixes; Editorial amendments.

	GLOBAL STANDARD	Page 3 of 36
	UP 2015 Box for outdoor installations	<b>GSTR001/3</b> Rev. 01

## INDEX

<b>1</b>	<b>ACRONYMS</b> .....	<b>4</b>
<b>2</b>	<b>INTRODUCTION</b> .....	<b>4</b>
<b>3</b>	<b>LIST OF COMPONENTS, PRODUCT FAMILY OR SOLUTIONS TO WHICH THE GS APPLIES</b> .....	<b>5</b>
<b>3.1</b>	<b>Enel Product family codes of the Outdoor Cabinets</b> .....	<b>5</b>
<b>4</b>	<b>APPLICABLE LAWS, REFERENCE STANDARDS AND GLOBAL STANDARDS</b> .....	<b>7</b>
<b>4.1</b>	<b>Applicable Laws and Standards</b> .....	<b>7</b>
<b>4.2</b>	<b>Enel Global Standards quoted in the document</b> .....	<b>8</b>
<b>5</b>	<b>CONSTRUCTION CHARACTERISTICS</b> .....	<b>8</b>
<b>5.1</b>	<b>Common features</b> .....	<b>8</b>
<b>5.1.1</b>	<i>Cable passage</i> .....	<b>8</b>
<b>5.1.2</b>	<i>Environmental Conditions</i> .....	<b>9</b>
<b>5.1.3</b>	<i>Content of the cabinet</i> .....	<b>9</b>
<b>5.2</b>	<b>Outdoor box – Standard version</b> .....	<b>16</b>
<b>5.3</b>	<b>Extended (XL) version of the Outdoor Cabinet container</b> .....	<b>22</b>
<b>6</b>	<b>EQUIPMENT TO BE PLACED INTO THE CABINET</b> .....	<b>24</b>
<b>6.1</b>	<b>PSBC</b> .....	<b>24</b>
<b>6.2</b>	<b>UE8</b> .....	<b>24</b>
<b>6.3</b>	<b>Batteries</b> .....	<b>24</b>
<b>6.4</b>	<b>Terminal board</b> .....	<b>24</b>
<b>6.5</b>	<b>Custom devices</b> .....	<b>28</b>
<b>6.6</b>	<b>Communication module</b> .....	<b>28</b>
<b>7</b>	<b>THERMOREGULATION SYSTEM</b> .....	<b>29</b>
<b>7.1</b>	<b>Solution with anti-condensation heater and temperature controller</b> .....	<b>29</b>
<b>7.2</b>	<b>Solution with heater</b> .....	<b>29</b>
<b>8</b>	<b>TESTING AND INSPECTION</b> .....	<b>30</b>
<b>8.1</b>	<b>Type tests</b> .....	<b>30</b>
<b>8.1.1</b>	<i>Visual inspection</i> .....	<b>30</b>
<b>8.1.2</b>	<i>Verification of all of the functionalities</i> .....	<b>30</b>
<b>8.1.3</b>	<i>Mechanical tests</i> .....	<b>30</b>
<b>8.2</b>	<b>Acceptance tests</b> .....	<b>31</b>
<b>9</b>	<b>POLE FASTENING SYSTEM</b> .....	<b>32</b>
<b>9.1</b>	<b>Mounting kit for poles with a squared section</b> .....	<b>32</b>
<b>10</b>	<b>AMBIENT OPERATING CONDITIONS</b> .....	<b>36</b>
<b>11</b>	<b>SUPPLY REQUIREMENTS</b> .....	<b>36</b>
<b>11.1</b>	<b>TCA documents and manuals</b> .....	<b>36</b>
<b>11.1.1</b>	<i>TCA documents</i> .....	<b>36</b>
<b>11.1.2</b>	<i>Manuals</i> .....	<b>36</b>
<b>11.1.3</b>	<i>Safety warnings on Plate</i> .....	<b>36</b>
<b>12</b>	<b>SAFETY REQUIREMENTS</b> .....	<b>36</b>

	GLOBAL STANDARD	Page 4 of 36
	UP 2015 Box for outdoor installations	<b>GSTR001/3</b> Rev. 01

## 1 ACRONYMS

<b>CPE</b>	Customer Premises Equipment
<b>FPI</b>	Fault Passage Indicator
<b>IC</b>	Customer Interface device
<b>LVCB</b>	Low Voltage Circuit Breaker
<b>LVI</b>	Line Voltage Indicator
<b>PSBC</b>	Power Supply Battery Charger
<b>RGDAT</b>	directional fault passage and voltage loss indicator
<b>RGDM</b>	directional fault passage indicator with measuring acquisition
<b>Recloser</b>	Pole-mounted switch breaker with integrated control module
<b>RTU</b>	Remote Terminal Unit for the remote control of the secondary substations
<b>SD</b>	Switch Disconnecter
<b>SG</b>	Switchgear
<b>TB</b>	Terminal Board
<b>UE</b>	Processing Unit of the RTU

## 2 INTRODUCTION

Enel standardized MV remote control solution for outdoor applications includes a Remote Terminal Unit (RTU) and, optionally, a fault detector installed in correspondence of the Line Out switch.

The Global Standard GSTR001 describes the standardized Remote Terminal Unit (RTU), also called UP, which can be used to remote control MV pole mounted switches, reclosers and circuit breakers.

This document describes the outdoor box for the Remote Terminal Unit designed for pole-mounting applications.

This specification aims at maintaining the compatibility between the existing equipment normally used for indoor installations (batteries, power supply, and UE) and provide solutions suitable for pole installations (interface with the UE via terminals, layouts of the terminals in order to interface them to new equipment, etc...).

	GLOBAL STANDARD	Page 5 of 36
	UP 2015 Box for outdoor installations	<b>GSTR001/3</b> Rev. 01

### 3 LIST OF COMPONENTS, PRODUCT FAMILY OR SOLUTIONS TO WHICH THE GS APPLIES

Two versions of the outdoor container have been defined:

- Standard version - OS-UP
- Extended version- OXL-UP.

Each one corresponds to a different product family code.

#### 3.1 Enel Product family codes of the Outdoor Cabinets

Global Product Family Code	Device Code	Description	Reference Global Standard	Included in the Global Product family code
519503		Complete UP kit for Outdoor application, mounted in the Wall-mounted indoor cabinet container	GSTR001/1 GSTR001/3	PSBC UE8 OS-UP
519545	OS-UP	Outdoor cabinet container for pole-mounted Remote Terminal Unit - standard version	GSTR001/3	
519546	OXL-UP	Outdoor cabinet container for pole-mounted Remote Terminal Unit - Extra-large version	GSTR001/3	

Description	Global Product Family Code	Argentina	Brazil	Chile	Colombia	Italy	Peru	Romania	Spain
Complete UP kit for Outdoor application, mounted in the Outdoor cabinet container	519503	0131-0404	6810357	6808328	6810357	519503	6810357	519503	510258

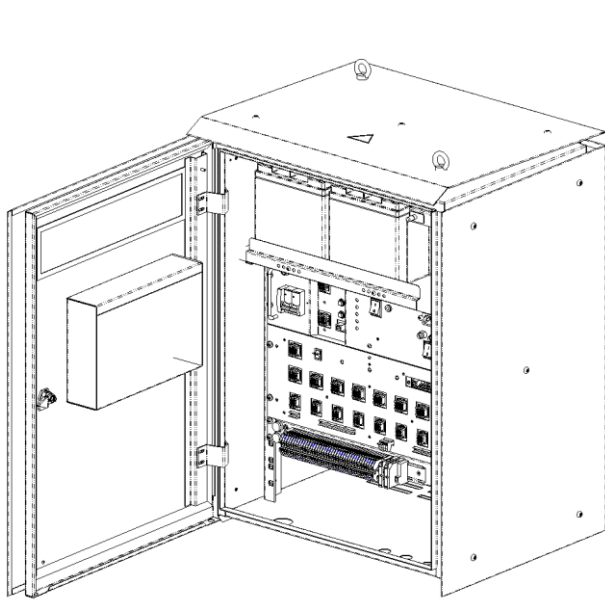

Figure 1 - OS-UP

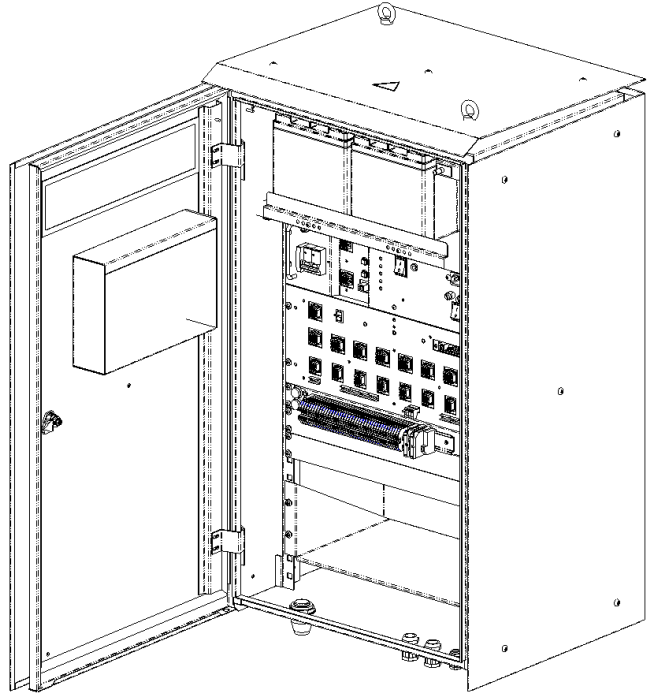



Figure 2 - OXL-UP

UP Outdoor Solutions

	GLOBAL STANDARD	Page 7 of 36
	UP 2015 Box for outdoor installations	<b>GSTR001/3</b> Rev. 01

Accessories	Solution	Description		Supplied
PSBC	OS-UP/ OXL-UP	Power supply/ battery charger of the RTU, switchgears and auxiliary devices (modem, router, etc.) with accessories	GSTR001/1	Yes
UE8	OS-UP/ OXL-UP	Processing Unit Device capable to telecontrol for 8 switchgears with accessories	GSTR001/1	Yes
Batteries	OS-UP/ OXL-UP	Couple of 12V batteries for remote control secondary substations	GSCB001	No
GSM/GPRS Modem	OS-UP/ OXL-UP	DCE for the remote connection		No
Terminal Board (TB)	OS-UP/ OXL-UP	Terminal board, either for the power supply of other devices, or for the local commands of the SG.		Yes
Thermoregulation system	OS-UP/ OXL-UP	Anti-condensing/heating system		Yes
Additional shelf	OXL-UP	Additional shelf for placement of auxiliary devices		Yes
Batteries	OS-UP/ OXL-UP	Batteries in compliance with the global specifications on batteries for secondary stations		No
SG-TB cable	OS-UP/ OXL-UP	Cable for the connection between the SGs and the TBs		Yes
FPI-TB cable	OS-UP/ OXL-UP	Cable for the connection between the FPI connector and the TB		Yes
PSBC-TB cable	OS-UP/ OXL-UP	Cable for the connection between the PSBC and the TB		Yes

#### 4 APPLICABLE LAWS, REFERENCE STANDARDS AND GLOBAL STANDARDS

##### 4.1 Applicable Laws and Standards

IEC 60068-2-6:2007	Environmental testing - Part 2-6: Tests - Test Fc: Vibration (sinusoidal)
IEC 60068-2-64:2008	Environmental testing - Part 2-64: Tests - Test Fh: Vibration, broadband random and guidance
ISO 1461:2009	Hot dip galvanized coatings on fabricated iron and steel articles — Specifications and test methods
ISO 9223:2012	Corrosion of metals and alloys -- Corrosivity of atmospheres -- Classification, determination and estimation
EN ISO 12944-2:1998	Paints and varnishes -- Corrosion protection of steel structures by protective paint systems -- Part 2: Classification of environments

	GLOBAL STANDARD	Page 8 of 36
	UP 2015 Box for outdoor installations	<b>GSTR001/3</b> Rev. 01

#### 4.2 Enel Global Standards quoted in the document

GSTR001/1	Remote Terminal Unit for secondary substations (UP)
GSTR001/2	UP - Box for indoor installations
GSTR001/3	UP - Box for Outdoor installations
GSCG002	Technical Conformity Assessment
GSCB001	12V Accumulators for remote control secondary substations
GSTP001	RGDAT-A70

## 5 CONSTRUCTION CHARACTERISTICS

Chapter 5.1 describes the design characteristics common to both the OS-UP and OXL-UP. Solutions. Chapters 0 and 5.3 describe the design characteristics specific for each of the two solutions, standard and XL, respectively.

### 5.1 Common features

#### 5.1.1 Cable passage

Both the cabinet containers (standard and extended versions) described in these specifications, are a variation of the box for indoor installation, as described in the GSTR001/2 specification. The container base must be provided with holes to pass the cables.

The cable glands used for the entrance on the bottom side of the container (included in the supply) must allow the passage of the cables listed below:

- Power supply cable, which must have a diameter equal to 16 mm;
- Cable for the connection to the switch disconnecter/circuit breaker, which must have a diameter equal to 20 mm;
- Antenna cable: jack must have a diameter equal to 9 mm;
- Ground earth should pass through bolt

The base of the container (Figure 3) must also be provided with a hole with a diameter of 35 mm, sealed with a cable glands for the RGDAT sensors. The internal diameter is equal to 21.5mm.

	GLOBAL STANDARD	Page 9 of 36
	UP 2015 Box for outdoor installations	<b>GSTR001/3</b> Rev. 01

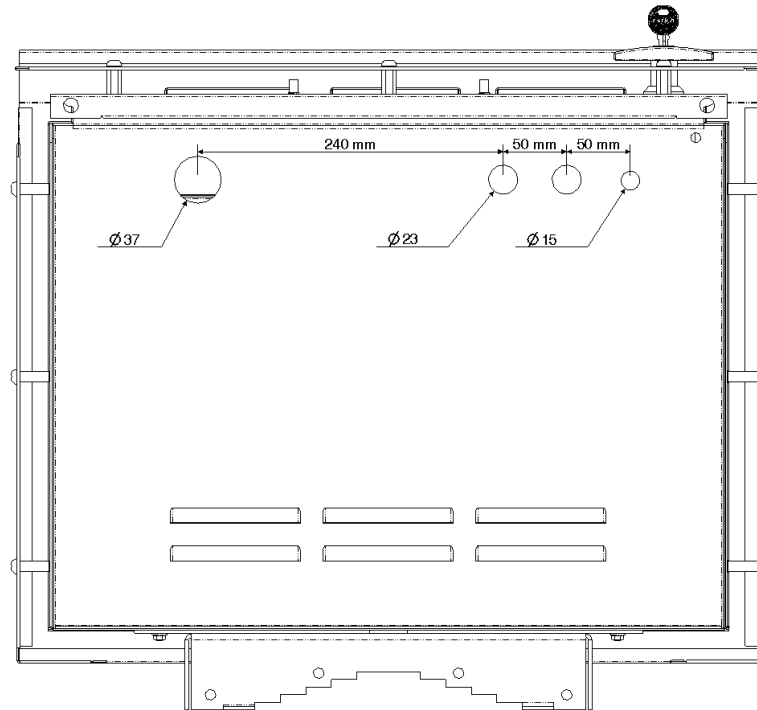

**Figure 3** – Layout of the container base

### 5.1.2 Environmental Conditions

All of the external surfaces of the cabinet container must ensure an effective and prolonged anti-corrosion effect.

In particular, the metal components of the box must be made of non-corrosive material or having been subject to the process of hot dip galvanization, in compliance with the ISO 1461 standard.

The cabinet container must have IP54 or higher degree of protection, and must be suitable to use in environmental conditions classified as climatic category type C5-M "Very High" (coastal areas with high salinity), in compliance with standards ISO 9223 and EN ISO 12944-2.

In the case the container is submitted to a hot dip galvanizing process, the minimum thickness of the coating must be equal to 100  $\mu\text{m}$  or, alternatively, the cabinet must have been previously subjected to a cathoporesis treatment.

### 5.1.3 Content of the cabinet

The content of the cabinet (UE panel, PSBC, and any other devices) shall be mounted on a 19" standardized rack frame. The box must be accessible from the front, and the rack frame must be of the unified multi-hole type.

**The rack frame should allow the insertion of devices with a depth up to 280mm.**

The batteries will be inserted on the shelf (Figure 4) positioned on the upper side of the container (space of 5U).



	GLOBAL STANDARD	Page 10 of 36
	UP 2015 Box for outdoor installations	<b>GSTR001/3</b> Rev. 01

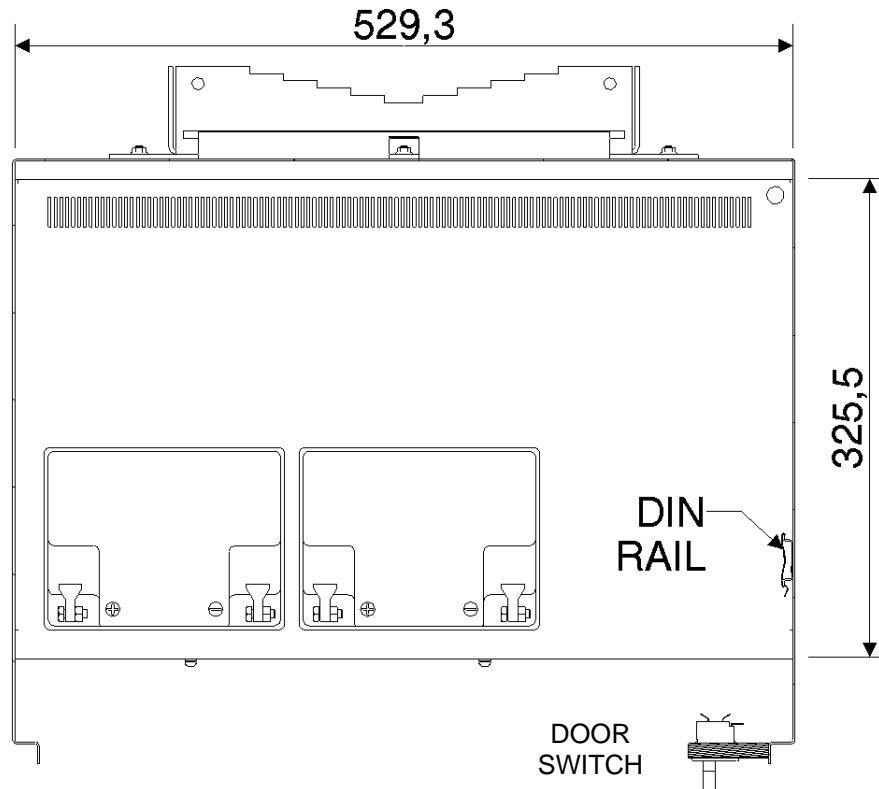

**Figure 4–** Horizontal section – batteries shelf

On one side of the container (Figure 4), corresponding to the battery cover, a (type omega) a DIN rail must be installed (Figure 5), which must be equipped with 2 clips and a circuit breaker which connect the secondary VT in order to simplify commissioning and maintenance.

The DIN rail with the circuit breaker can be installed also in the lower part of the box, to guarantee easiness of installation.

The other side of the circuit breaker will be pre-wired to the expected loads (PSBC, heater, etc ...).

**The default position of the breaker must be OFF position.**

Alternative solutions to the breaker, aimed to guarantee the safety during the connection of the VT, must be proposed to Enel for acceptance (e.g. a sectionable terminal board).

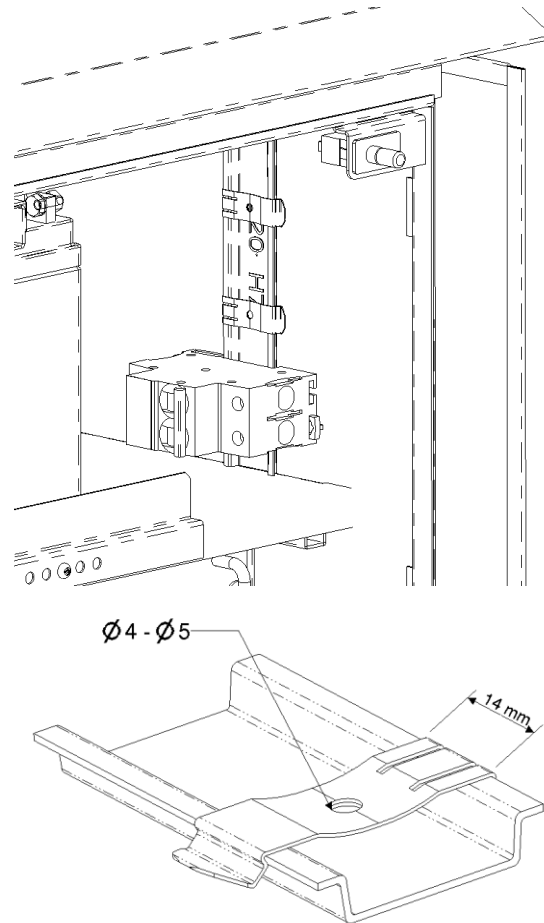

**Figure 5** – DIN rail with circuit breaker and applied clip (detail).

All the grounding braids are included in the supply.

The grounding braids must have a section at least equal to 16 mm<sup>2</sup> and include the connection of the grounding bolts (Figure 6) of the individual panels with the grounding bolt placed on the container.

The metal container must be provided with a grounding bolt for the connection of either the +24V<sub>DC</sub> power supply or the eventual exposed-conductive-parts.

	GLOBAL STANDARD	Page 12 of 36
	UP 2015 Box for outdoor installations	GSTR001/3 Rev. 01

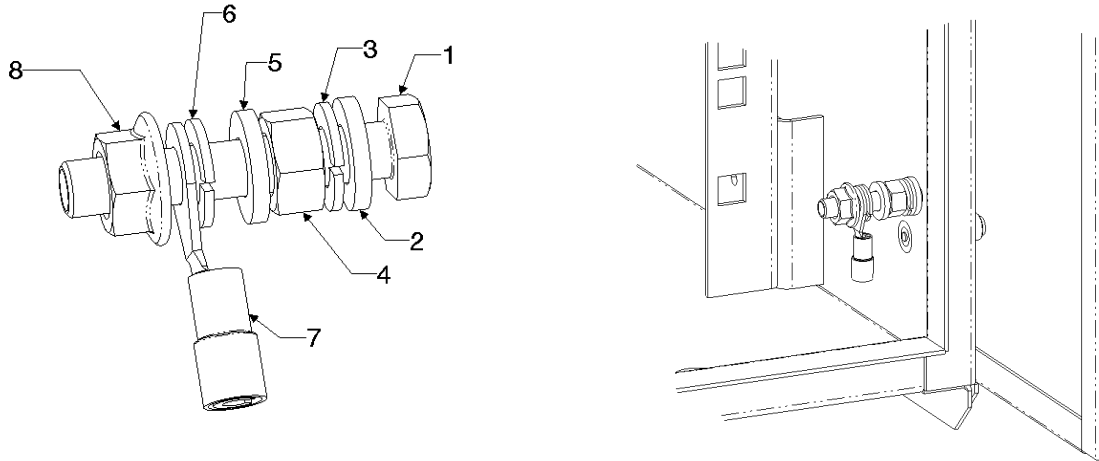

**Figure 6 - Grounding bolt**

The container must be equipped with lifting eyebolts to help the transport and installation of the RTU.

The container must be provided with proper solutions to limit the risk of overheating, due to the direct solar radiation (such as air inlets/outlets, reflector panels or ventilated wall chambers).

The panel must project beyond the front door. The access door must allow for the insertion/removal of all of the equipment housed in the container. Once the door is closed, it must be locked with a security lock with a key (see Figure 7).

The cabinet container must be provided with a system allowing the rainwater to runoff (such as an inclined panel, as shown on the top of Figure 11).

	GLOBAL STANDARD	Page 13 of 36
	UP 2015 Box for outdoor installations	<b>GSTR001/3</b> Rev. 01

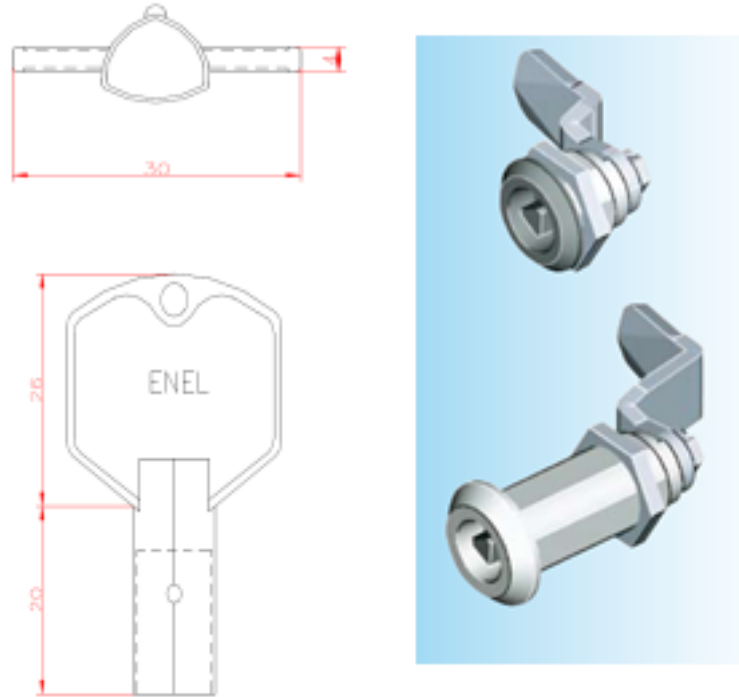

**Figure 7** – Standard Enel Key with a triangle of 6,5mm and examples of metallic door locks to be used.

On the inside of the front door it must be possible to house a fault detector (RGDAT/RGDM).

For this reason the door must have an adequate profile (as to the depth) in order to allow placing the devices without producing any contact or interference upon door closing and cables wiring.

The maximum size to be considered for the RGDAT/RGDM is: LxHxW: 300x200x70 [mm].

For the RGDAT/RGDM mounting pattern, refer to the diagram which is provided in Figure 8.

4 fixed bolts must be present in the internal side of the front door: each one must be equipped with a washer and a nut, see Figure 9 and Figure 10.

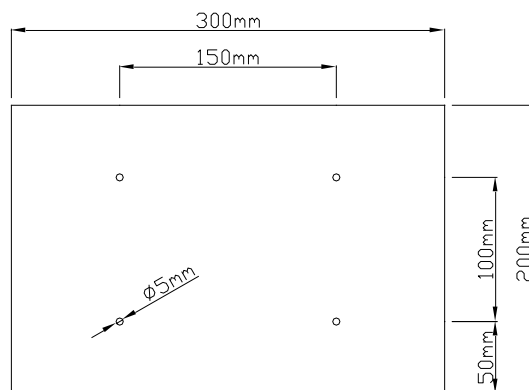

**Figure 8** – Mounting pattern of the RGDAT/RGDM

	GLOBAL STANDARD	Page 14 of 36
	UP 2015 Box for outdoor installations	<b>GSTR001/3</b> Rev. 01



**Figure 9** – 4 Fixed bolts (washers and nuts must be on every bolt)



**Figure 10** – Detail of washer and nut on the bolt

A contact must be provided, capable to communicate the door opening to the RTU, by means of a connection to the “Door Opening” Remote Signal.

The air inlets must be equipped with an anti-insect net.

All of the cables leading from either the switch disconnect or the circuit breaker, which is mounted on the top of the pole, or the antenna, run along the pole, toward the base of the RTU container, and are mechanically protected by a fiberglass channel (Figure 11).

In order to avoid water infiltrations inside the container, a coiled sheath, properly curved, protects the last section of the cables, from the end of the fiberglass channel, toward the RTU container.

	GLOBAL STANDARD	Page 15 of 36
	UP 2015 Box for outdoor installations	<b>GSTR001/3</b> Rev. 01

An entrance must be available for the cables of the switch disconnecter, the 100V<sub>CA</sub> power supply derived from the transformer, the antenna, and all of the spare RMs and RSs if any.

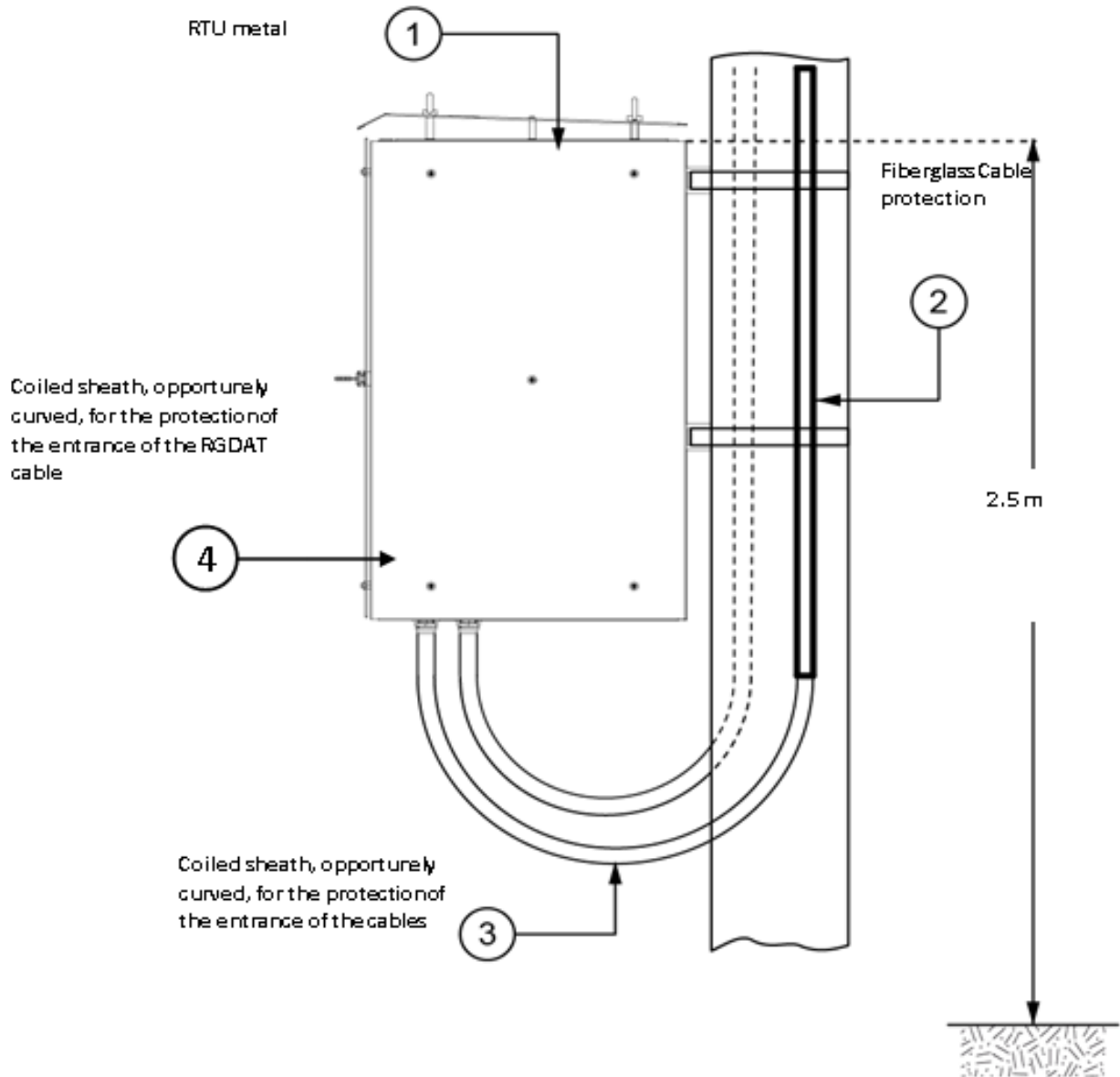

**Figure 11** – Installation example

## 5.2 Outdoor box – Standard version

The standard version of the outdoor cabinet must be suitable to house devices with total height of 15U. The size of the standard version of the outdoor cabinet container is shown in Figure 12, Figure 13, Figure 14.

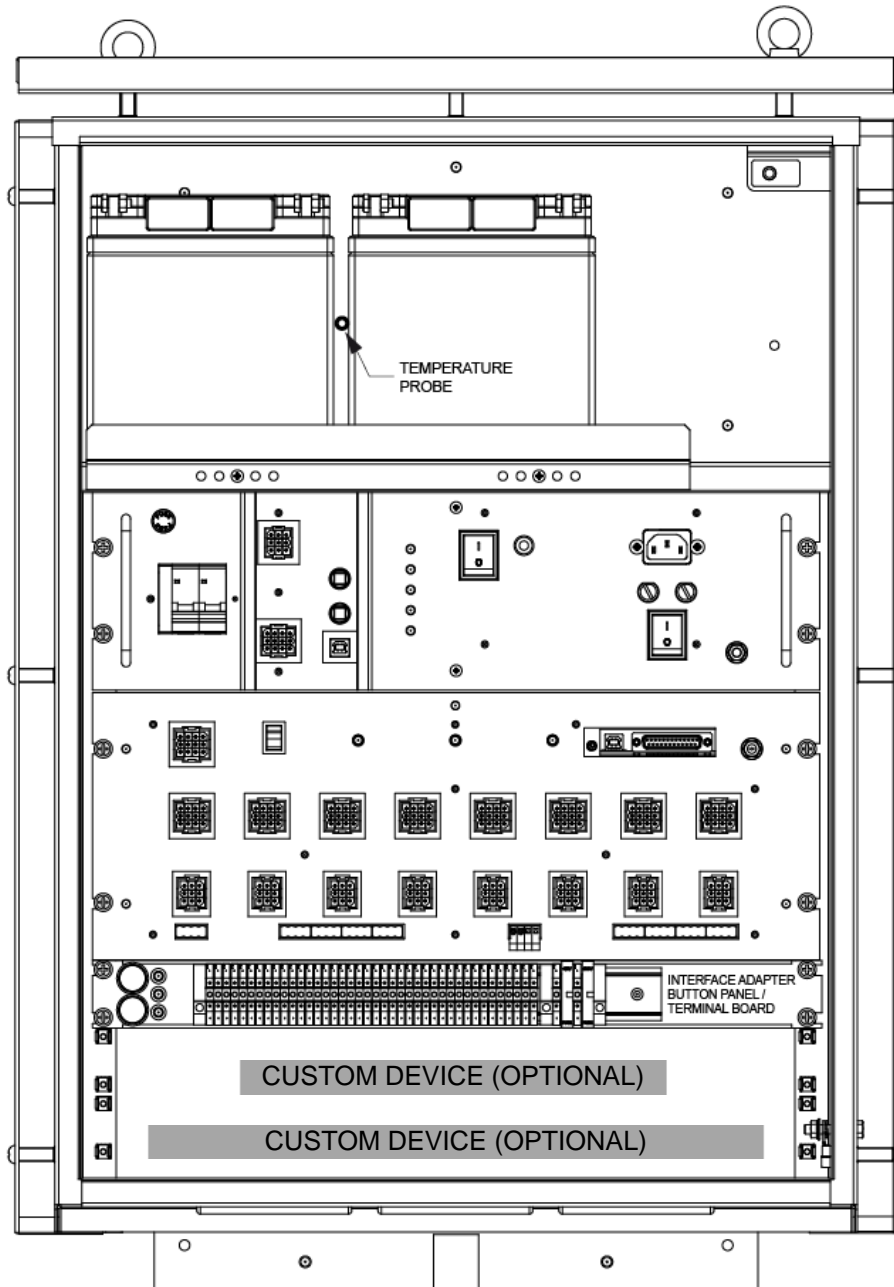
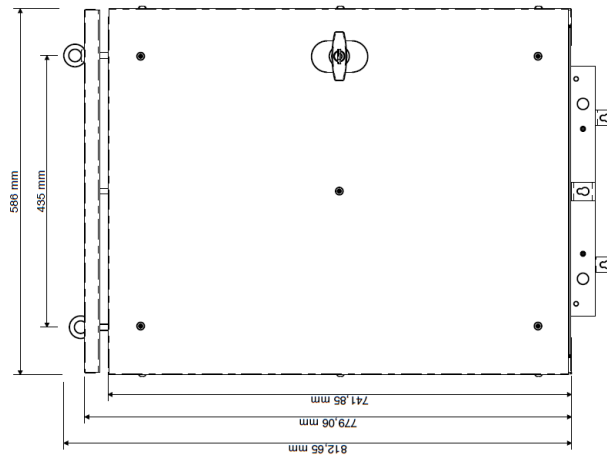
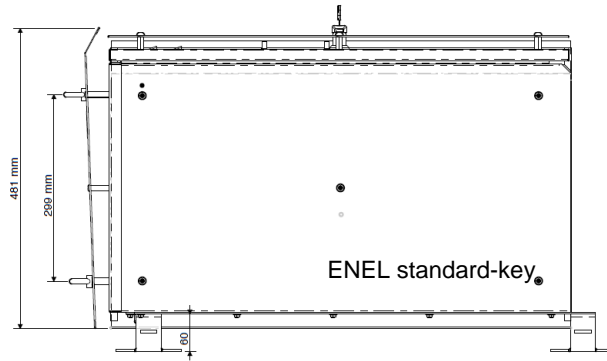
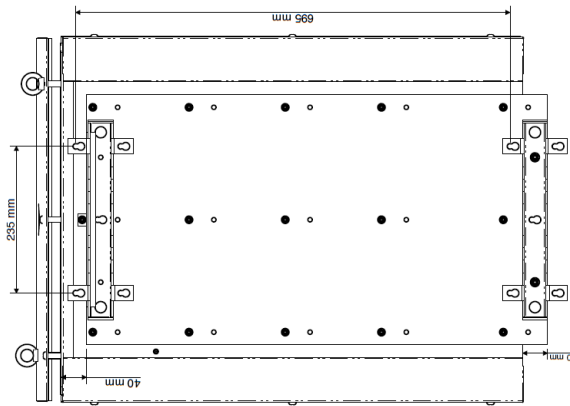



**Figure 12** – Front view of the Standard version of the outdoor cabinet container.

	GLOBAL STANDARD	Page 17 of 36
	UP 2015 Box for outdoor installations	<b>GSTR001/3</b> Rev. 01



	GLOBAL STANDARD	Page 18 of 36
	UP 2015 Box for outdoor installations	<b>GSTR001/3</b> Rev. 01



	GLOBAL STANDARD	Page 20 of 36
	UP 2015 Box for outdoor installations	<b>GSTR001/3</b> Rev. 01

**Figure 13** – Standard version of the Outdoor Cabinet container- Front/Left Side

	GLOBAL STANDARD	Page 21 of 36
	UP 2015 Box for outdoor installations	<b>GSTR001/3</b> Rev. 01

The front door must be hinged on a side, and equipped with a door-lock compliant with the ENEL standard key as shown in Figure 7.

With reference to the battery compartment, the horizontal plane must be provided with a small edge to avoid the batteries slipping out from the front (Figure 14 and Figure 15).

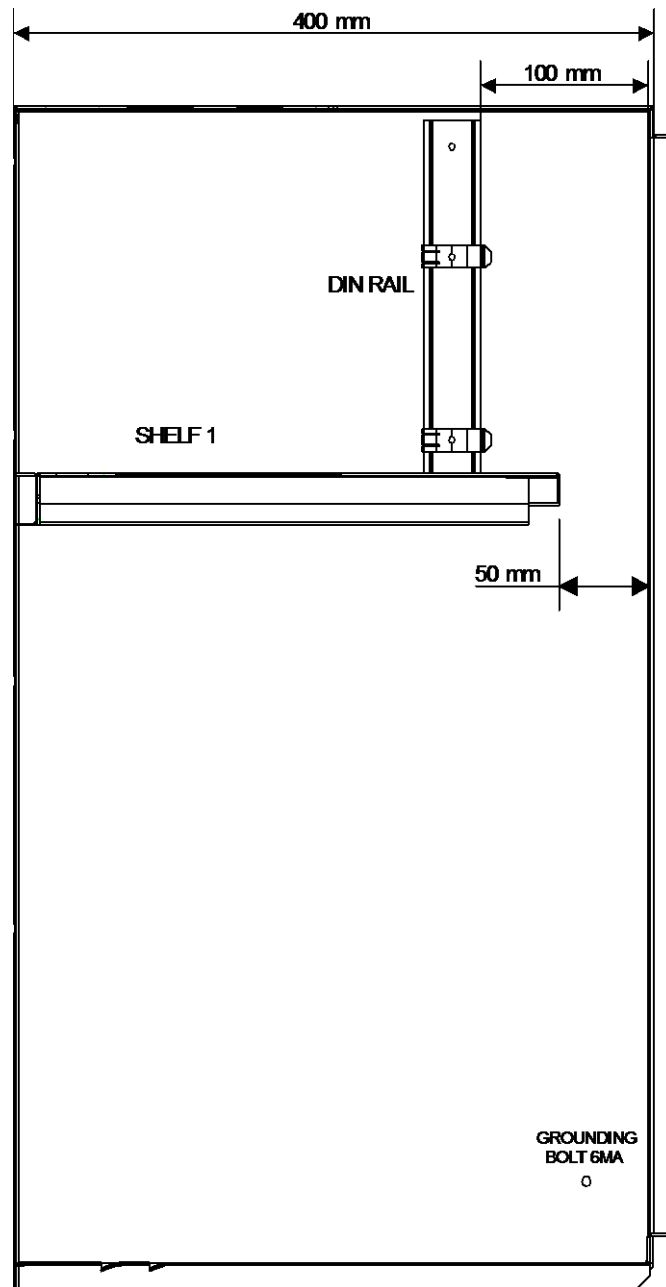
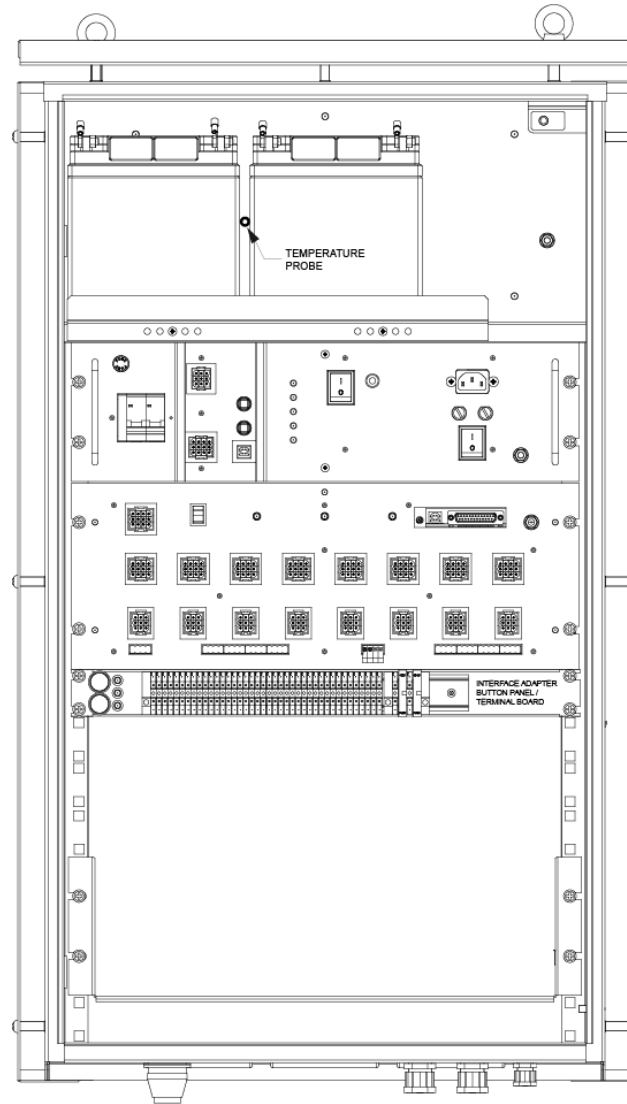

**Figure 14** – Standard version of the Outdoor Cabinet container-Side view

	GLOBAL STANDARD	Page 22 of 36
	UP 2015 Box for outdoor installations	<b>GSTR001/3</b> Rev. 01

**5.3 Extended (XL) version of the Outdoor Cabinet container.**

The extended version of the outdoor cabinet differs from the standard version in the vertical size (Figure 15). The cabinet shall have an overall height equal to 20U.



**Figure 15 – XL version of the Outdoor Cabinet container– front view**

	GLOBAL STANDARD	Page 23 of 36
	UP 2015 Box for outdoor installations	<b>GSTR001/3</b> Rev. 01

Moreover, in this configuration, the box must be equipped with an additional shelf (Figure 16), which is useful to house other supplementary equipment. The fixing support must have a height of 3U.

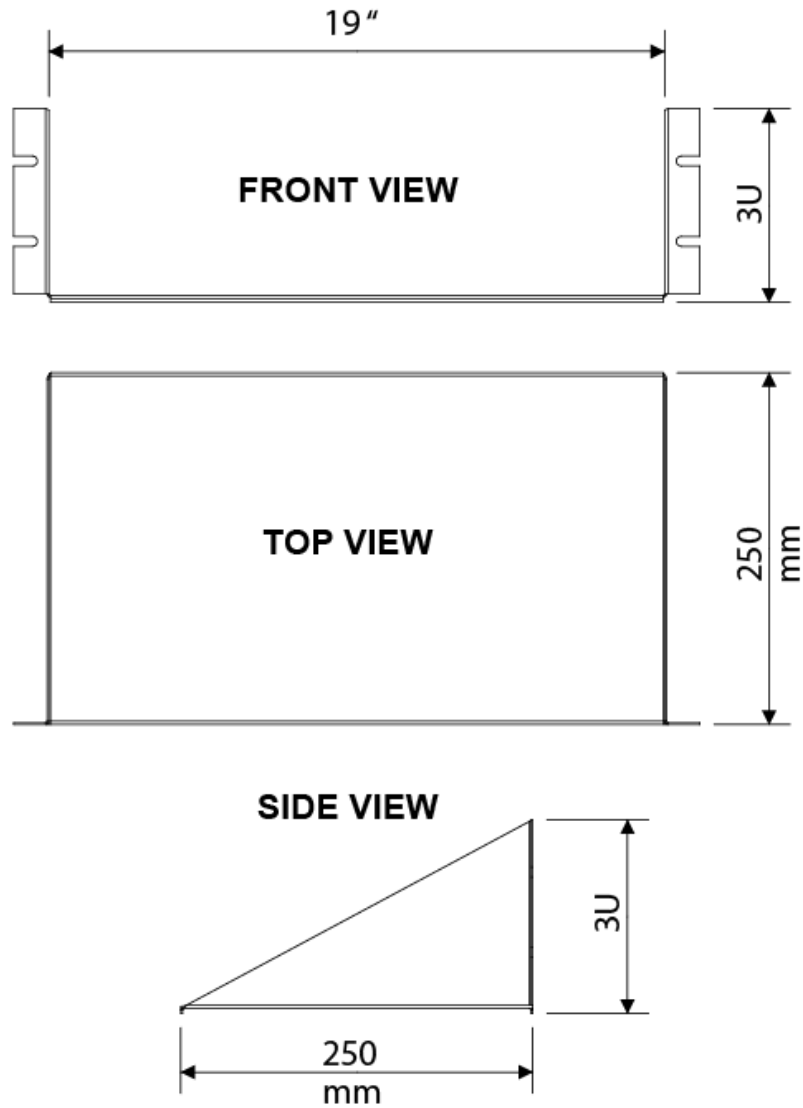

**Figure 16 – Shelf for the XL version**

	GLOBAL STANDARD	Page 24 of 36
	UP 2015 Box for outdoor installations	<b>GSTR001/3</b> Rev. 01

## 6 EQUIPMENT TO BE PLACED INTO THE CABINET

The cabinet is designed to host the equipment described in the Global Standard GSTR001/1.

The UE which is referred to throughout this specification represents the 8-channel "basic" version, namely UE8.

According to different specific applications, the Outdoor UP can be assembled in different configurations, containing all of or a subset of the following components:

- Power supply/battery charger (PSBC) with accessories;
- UE (UE8 version) with accessories;
- Batteries
- Terminal boards for the interface with the switchgears and the RGDAT/RGDM, and the power supply terminal boards
- Custom devices
- Communication module
- Other items to be installed on the additional shelf included in the OXL-UP version only

### 6.1 PSBC

The UP Battery Charger/Power supply, called PSBC, is described into the Global Standard GSTR001/1.

The PSBC has to be assembled on a 19" rack, with screws and cage bolts included in the supply. The overall height is equal to 3U.

### 6.2 UE8

The UP Processing Unit Device, available in two different versions is described into the specification GSTR001/1. Only the UE8, capable to manage up to 8 switchgears, is applicable to the Outdoor UP solution.

The UE8 has to be assembled on a 19" rack, with screws and cage bolts included in the supply. The overall height is equal to 4U.

### 6.3 Batteries

The batteries must be compliant with the Global Standard GSCB001 and they shall be housed inside a proper compartment, as shown in the Figures of the previous chapters of this specification.

### 6.4 Terminal board

Only part of the 8 channels on the UE8 will be normally used in outdoor applications. The interface among the UE and switchgear (SG), and Fault Detector (FPI, i.e. RGDAT/RGDM) and power supply terminal boards must be designed as follows:

- Channel 1: SG and FPI connectors, leading from the RTU, will be made available on the pre-wired terminal board.
- Channels 2, 3,..,8: SG and FPI connectors of the UE are available for a direct connection.

The connectors for SG and DFPI must be easily identifiable by a separator, a distance or a differentiated color.

The terminal board must be assembled on a 19" rack (with an overall height equal to 1U) with the screws and cage bolts included in the supply.

The technical solution, as well as the layout of the terminals provided with a fuse holder, must be compliant with the one shown in Figure 17, in order to contain the overall height within 1U. Figure 17 also shows the trimmers (which are housed on the same bracket) for the adjustment of the thresholds of the temperature, and the humidity for the thermoregulation system.

	GLOBAL STANDARD	Page 25 of 36
	UP 2015 Box for outdoor installations	<b>GSTR001/3</b> Rev. 01

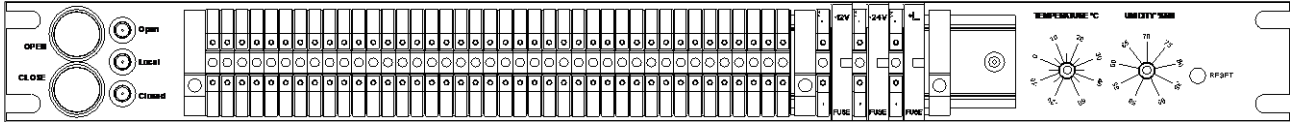

**Figure 17** – Terminal board, example of solution.

The serigraphies must clearly indicate the pin number, and if possible, the function, with the synthetic name reported in Table 1 and Table 2. On the internal part of the door, a label will always be present for decodification of the terminal board components.

The connection from SG and DFPI cables to the terminal, can be performed by a connector, with Molex format, as in the example of Figure 18.

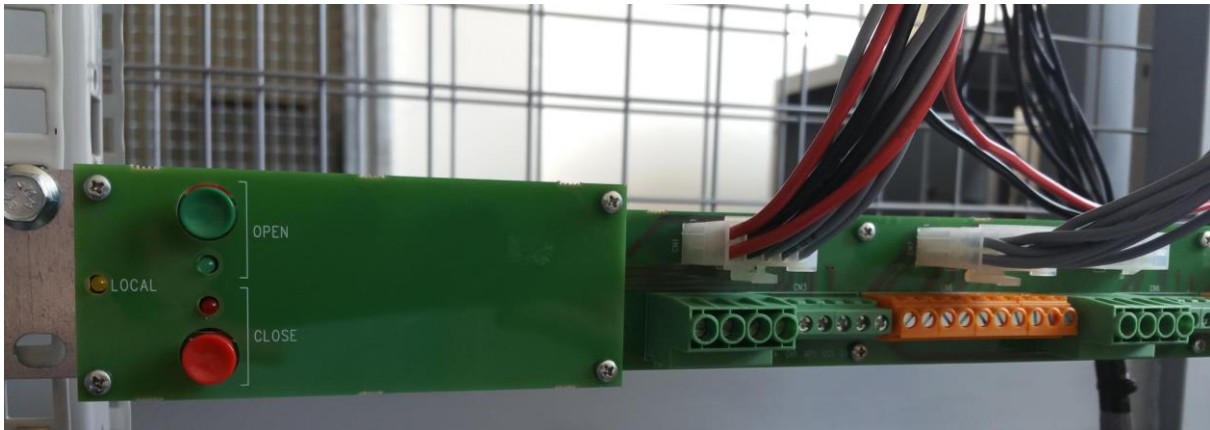

**Figure 18** – Cables from SG and DFPI connection to the terminal board by means of Molex connector

The 3 LEDs at the left side of Figure 17, which indicate the open or closed position of the SG, and the local control configuration, respectively, must be available on the terminal board.

The board must allow the opening and closing of the switchgear, through a pair of buttons (green for the opening, red for the closure) which will be active only if the RTU is under local control.

Under local control, the L+ signal provided on the terminal board has the high level, + 24V.

Figure 19 shows the detail of the terminals for the connection of the power supplies and the distribution to other devices. The negative terminals of the power supplies (nr. 1 at 12V and nr. 3 at 24V) will be equipped with fuse holders and 2.5 A fuses, on the load side.



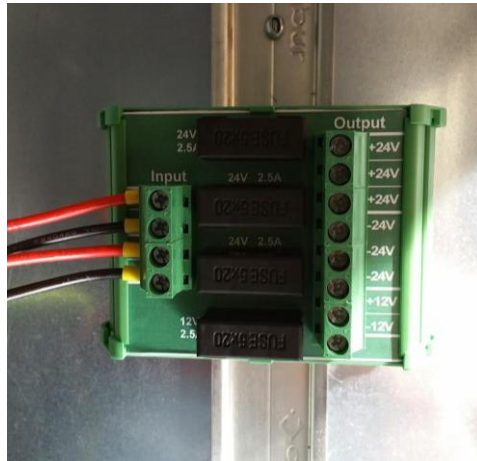

**Figure 19** – Terminal board for the distribution of the auxiliary power supplies

All of the terminals of this board must be provided with a screw tightening, for all of the cables with a section equal to 1,5mm<sup>2</sup>. The connections to the battery poles, red for the positive and black for the negative, must have: a section  $\geq 3\text{mm}^2$  (2x1,5 mm<sup>2</sup>), a length  $\geq 80\text{cm}$  and, on the battery side, a collar label indicating the respective polarity and ring terminal connector for screw size M8 assembled in factory.

The wiring between the connectors of channel 1 on the UE and the terminal board will be via two cables included in the supply.

Each terminal must allow easy identification of the corresponding associated signal, according to the naming defined for them as in the GSTR001/1 specification, as shown in the following Table 1, Table 2 and Figure 20. Their name may be also quoted on the board itself.

IMS	Function		Peripheral Unit
	Signal	Description	
1	+M	Motor power supply (+24 V <sub>DC</sub> )	1
1	+M	Motor power supply (+24 V <sub>DC</sub> )	1
2	-M	Motor power supply (-24 V <sub>DC</sub> )	2
2	-M	Motor power supply (-24 V <sub>DC</sub> )	2
3	+A	Commands power supply (+24 V <sub>DC</sub> )	3
4	-A	Commands power supply (-24 V <sub>DC</sub> )	4
5	89CX	Closing command	5
6	89AX	Opening command	6
7	89ccx	Signal closing position switch-disconnector	7
8	89cax	Signal opening position switch-disconnector	8

**Table 1**– Pin out of the SG terminals

	GLOBAL STANDARD	Page 27 of 36
	UP 2015 Box for outdoor installations	<b>GSTR001/3</b> Rev. 01

Terminal of the Interface board	Function		Pin of the FPI connector on the UE
1	COM RS	(+24 V <sub>DC</sub> ) Power supply and Common	1
2	51S	Overcurrent tripping	2
3	RS	RS Spare	3
4	TM	Measurement input (pole 1)	4
5	67S	Zero sequence directional tripping	5
6	TM	Measurement input (pole 2)	6
7	COM DO	Common Digital Output	7
8	DO	Digital Output	8
9	-	Power supply (-24 V <sub>DC</sub> )	9

**Table 2** – Pin out of the FPI terminals

Nevertheless, NOT pre-wired terminals must be provided in order to connect an additional SG/FPI channel.

The following items must be provided in the supply:

- Nr. 1 11-wire cable, called the "SG-TB cable", provided with:
  - the "SG" male 12-socket connector, on one end, compliant with the GSTR001/1 specification;
  - pre-wired cables on the terminal board (Molex), on the other end, with same pin numbering of the 12-socket pin connector
- Nr. 1 9-wire cable, called the "FPI-TB", provided with:
  - the FPI 9-socket male connector, on one end, compliant with the GSTR001/1 specification;
  - pre-wired cables on the terminal board (Molex), on the other end, with same pin numbering of the 9-socket pin connector.

Any other cables of the above mentioned types can be requested and supplied as spare accessories.

	GLOBAL STANDARD	Page 28 of 36
	UP 2015 Box for outdoor installations	<b>GSTR001/3</b> Rev. 01

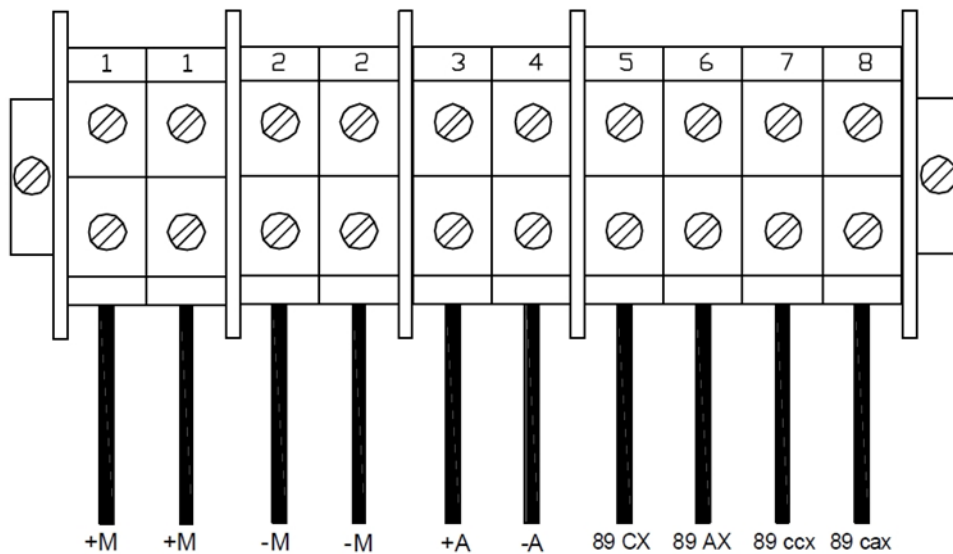

**Figure 20** - Pre-wiring of the terminal board, in detail.

## 6.5 Custom devices

It has to be possible to place one or more custom devices on the 19" rack with the screws and cage bolts included in the supply. The overall height that must be made available is equal to 2U.

## 6.6 Communication module

This module is an integrated device, which can be constituted by either a GSM/GPRS modem or a CPE device, connected to either the UE8 or other Router interfaces, via the standard serial interface. The device allows the connection of the RTU to the Central System, through various possible communication networks.

The module is powered via the 12V<sub>DC</sub> output, provided for on purpose and derived from the TB-AUX terminal board.

	GLOBAL STANDARD	Page 29 of 36
	UP 2015 Box for outdoor installations	<b>GSTR001/3</b> Rev. 01

## 7 THERMOREGULATION SYSTEM

A system must be provided for the thermoregulation of the RTU, in order to guarantee an outdoor operating temperature in the range  $-20^{\circ}\text{C} \div 55^{\circ}\text{C}$ .

Alternative proposals, which differ from the two solutions described below, can be accepted, but they must be agreed in advance and approved by ENEL.

### 7.1 Solution with anti-condensation heater and temperature controller

A (100V<sub>AC</sub>) 50W sized anti-condensation heater is provided, housed as low as possible within the container, and it has to be protected by a grid, to avoid accidental contact with the conductors.

Moreover, a temperature controller (shown in the diagram of Figure 21) must be housed in the cabinet container, which includes both humidity and temperature probes, which controls the anti-condensation heater, in order to guarantee standard climatic conditions within the container.

Using trimmers placed on the terminal board, the temperature and humidity threshold levels may be regulated within the given ranges which are listed below:

Temperature:  $-20^{\circ}\text{C} \div + 55^{\circ}\text{C}$ ;

Relative Humidity:  $50 \div 90\%$ .

In case of failure or short-circuit of the anti-condensation heater (blown fuse), a warning alarm must be generated by the UE, which will in turn send it to the Center, using a spare RS.

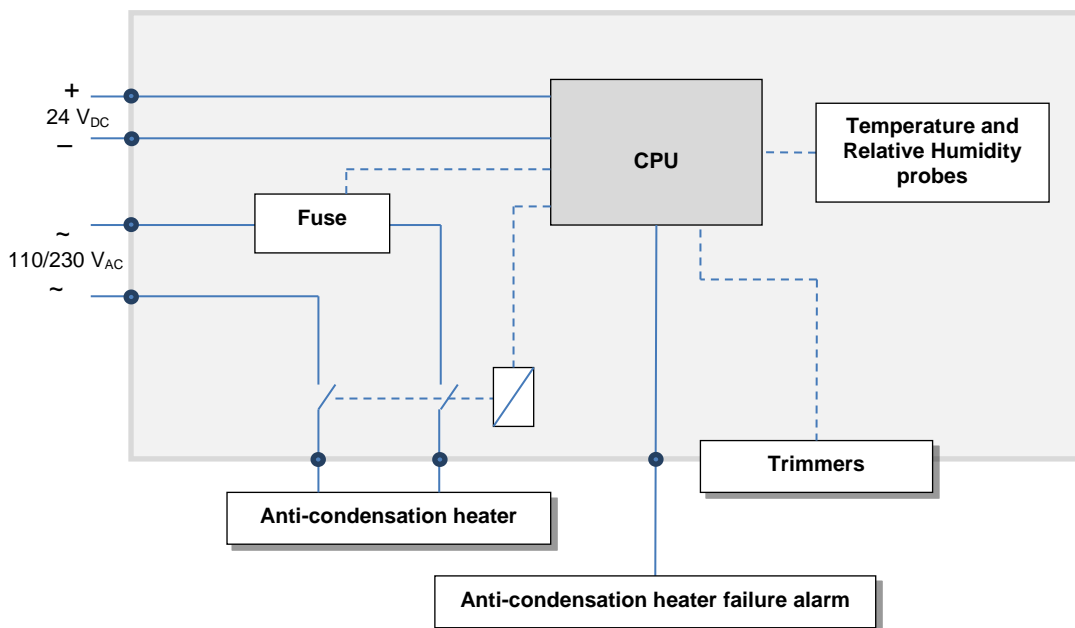



Figure 21 – Anti-condensation heater and temperature controller

### 7.2 Solution with heater

If the controller is mounted in a watertight cell, the variations of the relative humidity of the external ambient could not be compensated. In this case, the heater can only control the temperature, through a thermostat, which is able to maintain the temperature of the watertight cell above the pre-set minimum operating threshold of the RTU.

The power of the heater may exceed 50W, though the overall consumption must be less than 200VA.

	GLOBAL STANDARD	Page 30 of 36
	UP 2015 Box for outdoor installations	<b>GSTR001/3</b> Rev. 01

In this case, a temperature probe, positioned opportunely, shall detect the failure of the thermoregulation system. The probe is configured so that an alarm is generated (acquired on the spare RS 8) whereas the internal temperature is out of the normal operating range.

## 8 TESTING AND INSPECTION

The testing and certification process for the UP and its components must be executed according to Enel Global Standard **GSCG002 - Technical Conformity Assessment**. That Global Standard describes the procedures for “technical conformity assessment” (hereinafter “TCA”) of components to be supplied (directly or indirectly) to all Enel Global Infrastructure and Networks Countries.

Before starting the supply, the UP and its components must receive the “Statement of Conformity”, according to GSCG002 prescriptions.

In addition to the tests prescribed in the GSTR001/1, the following tests must be executed:

- Type tests, with the aim to verify the perfect compliance of a production item with the technical specifications detailed in the present document;
- Acceptance tests, with the aim to control the essential characteristics of each item of the supply.

### 8.1 Type tests

The supplier must maintain and provide ENEL with access to the documentation which attests to the successful execution of the type tests.

#### 8.1.1 Visual inspection

It is mandatory to verify the absence of visible manufacturing defects, the accuracy of construction, the compliance of the dimensions of the cabinet container with those indicated in the present specification, as well as the prescribed IP degree of protection and prescriptions related to the environmental conditions.

#### 8.1.2 Verification of all of the functionalities

All of the functionalities of either the thermoregulation system or of the terminal board controls must be verified.

#### 8.1.3 Mechanical tests

The tests to be executed on the cabinet container, as well as the methodology of the execution of these tests, are described within the standards recalled in the following table.

TEST	DESCRIPTION	REMARKS
<b>STATIONARY VIBRATION (SINUSOIDAL)</b>	<ul style="list-style-type: none"> <li>• Displacement amplitude (mm) : 0,75</li> <li>• Acceleration amplitude (m/s<sup>2</sup>) : 10</li> <li>• Frequency range (Hz): 10-500</li> <li>• Duration: 5 cycles per axis</li> <li>• Fixing points: those of the standard mounting structure, considering the UP full equipped without batteries.</li> <li>• Acceptance criteria: Correct operation of the device during the test (e.g. execution of open/close commands on a switch)</li> </ul>	<b>Reference standard: EN 60068-2-6 (method Fc)</b>
<b>STATIONARY VIBRATION (RANDOM)</b>	<ul style="list-style-type: none"> <li>• Spectrum A.1 “Transportation” – Tab.A2 – Category 2 (EN 60068-2-64)</li> <li>• Duration: 0.5 hours per axis (3 axis)</li> <li>• Fixing points: as in standard shipping position without package.</li> <li>• Acceptance criteria: No damage of the device</li> </ul>	<b>Reference Standard: EN 60068-2-64 (method Fh)</b> Category: 2 (transportation-water, trailers, lorries, in areas with well developed road systems)

These tests must be executed with all panels supplied mounted inside the Box, reproducing:

	GLOBAL STANDARD	Page 31 of 36
	UP 2015 Box for outdoor installations	<b>GSTR001/3</b> Rev. 01

- The operation condition in case of sinusoidal vibrations**  
Sinusoidal vibration tests (IEC 60068-2-6) must be performed on the assembled device, in normal operation conditions and mechanical fixation, with the device in operation.
- The transport conditions in case of random vibrations**  
Random vibration tests (IEC 60068-2-64) must be performed on the assembled device, in the same condition as the device will be shipped, and using mechanical fixation methods allowed by IEC 60068-2-64.

## 8.2 Acceptance tests

Within the overall set of type tests, a subset of tests will be selected (i.e. the functionality of the thermoregulation system), mandatory for the acceptance of each specimen of supply.

For each item supplied, a certificate must be provided, which attests to the success in the execution of the acceptance test.

	GLOBAL STANDARD	Page 32 of 36
	UP 2015 Box for outdoor installations	<b>GSTR001/3</b> Rev. 01

## 9 POLE FASTENING SYSTEM

The pole fastening system, as well as the number of holes and their dimensions, must be defined by the constructor. This in order to guarantee the stability of the entire structure due to an overload equal to twice the equipment weight, for either the standard or the extended versions.

It must be possible to fix the container to the pole (Figure 22 – Pole installation) at approximately 2.5 m above the ground, so that the front panel door must be accessible by using a ladder set up on the pole.

**Given that the pole diameter must have a range between 30 and 50 cm, it is recommended that a fastening system be constituted of a stainless steel band with clip.**

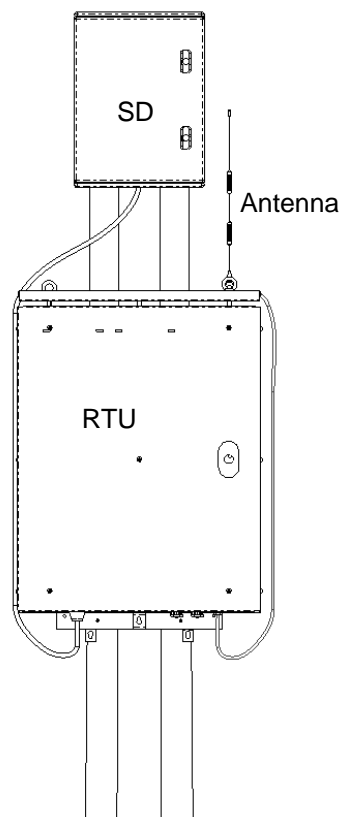

**Figure 22 – Pole installation**

Components used for the proper assembly of the RTU are described in Figure 24; all the external components or hanging accessories must ensure effective and prolonged anti-corrosion properties according to the same requirements stated in **Chapter 5.1.2 - Environmental Conditions**.

The hanging systems must be engineered so as to withstand the weight of the RTU fully equipped and, in any case, no less than 120kg

A plate (B) is mounted at the rear of the RTU, with the upper edge curved in order to allow the RTU to be hooked on the support (A). This last must be fixed in advance to the pole with metal clamps.

### 9.1 Mounting kit for poles with a squared section

In case of poles having a squared section, an optional kit (C) must be engineered to be adopted as an additional accessory in the countries where these kind of poles are frequently used (see **Figure 23** part C). This Kit includes all the necessary bolts, screws and everything necessary to guarantee a proper installation.

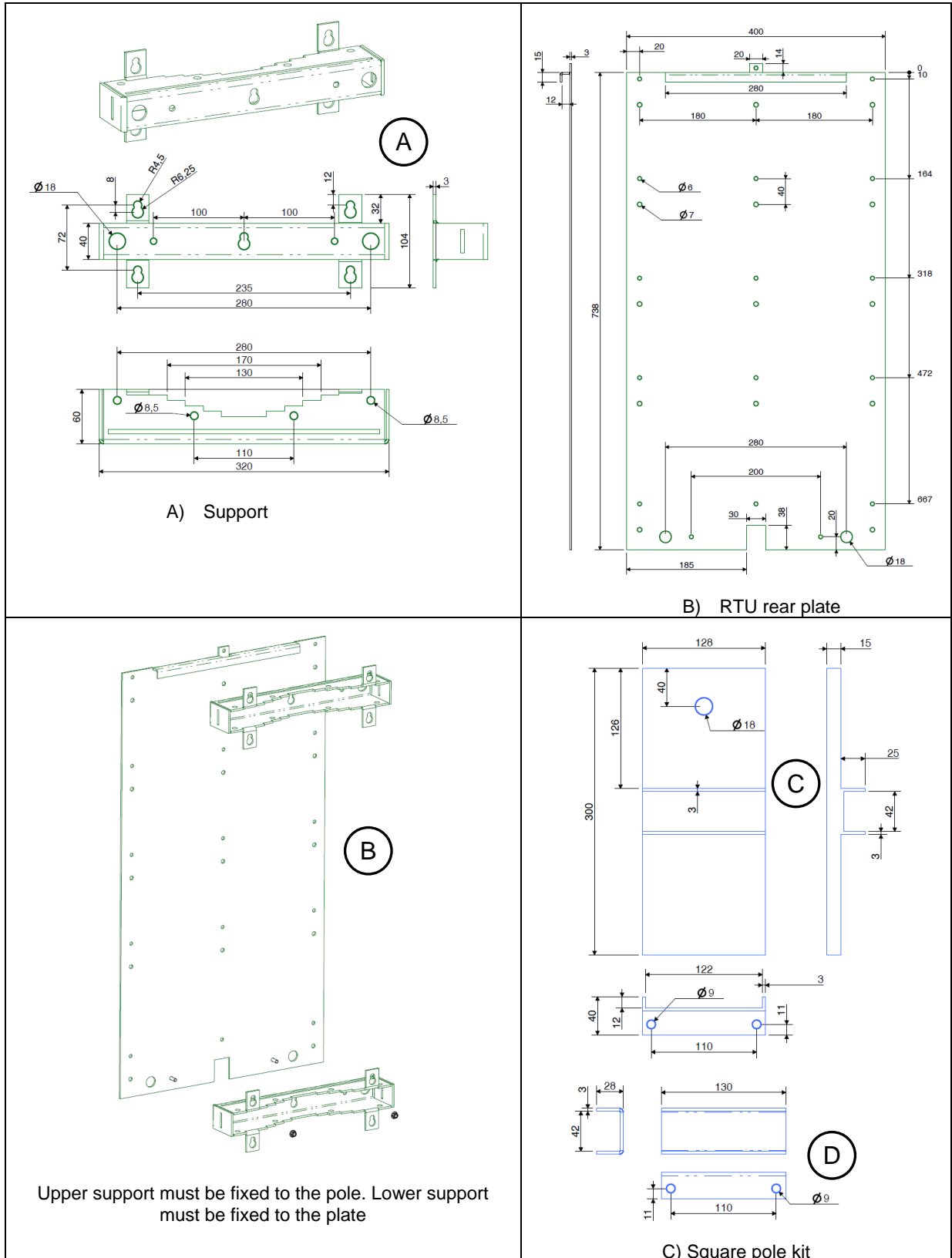

Figure 23 – RTU pole mounting kit



Not supplied by the manufacturer

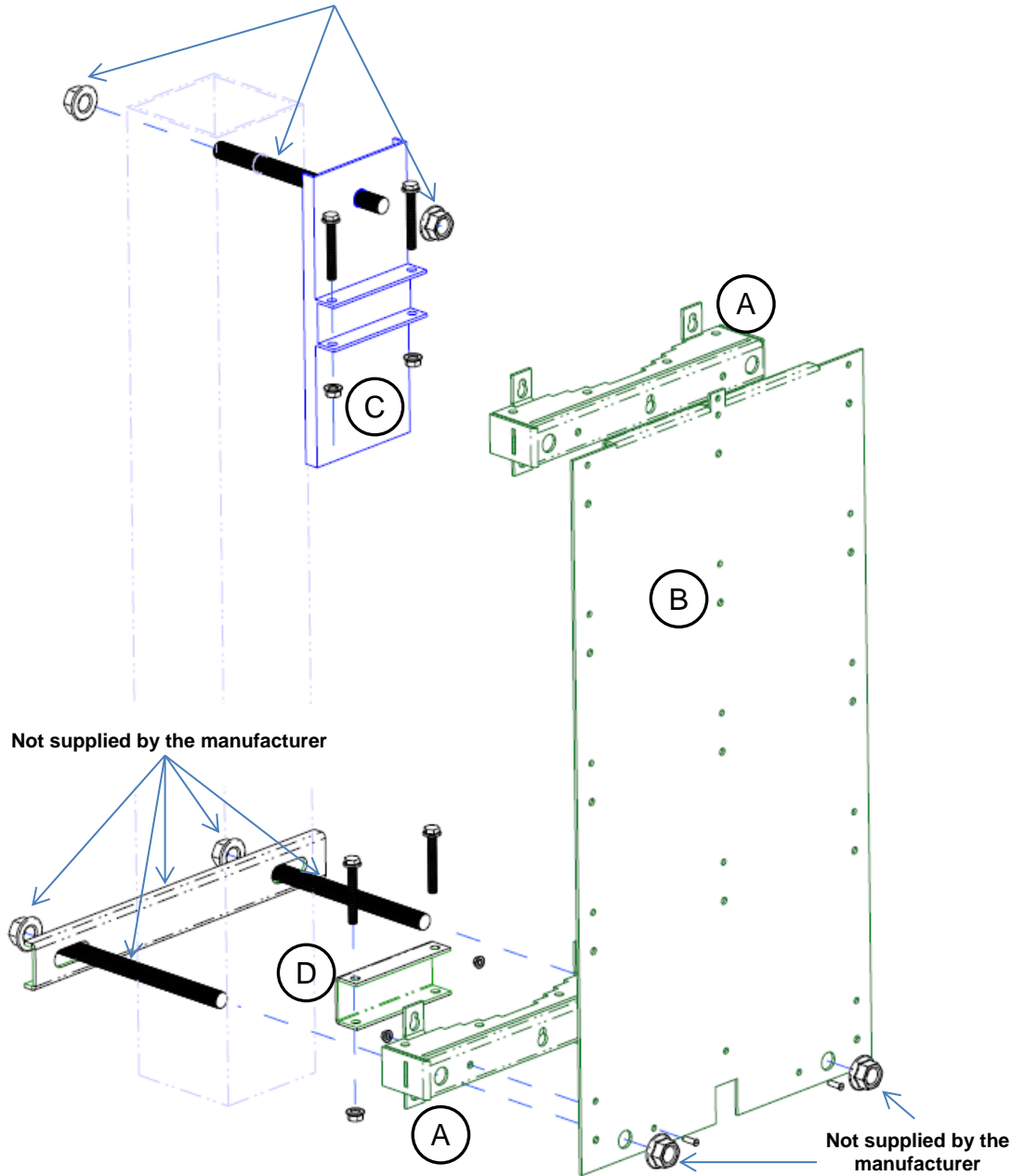

Figure 24 – Square pole mounting example

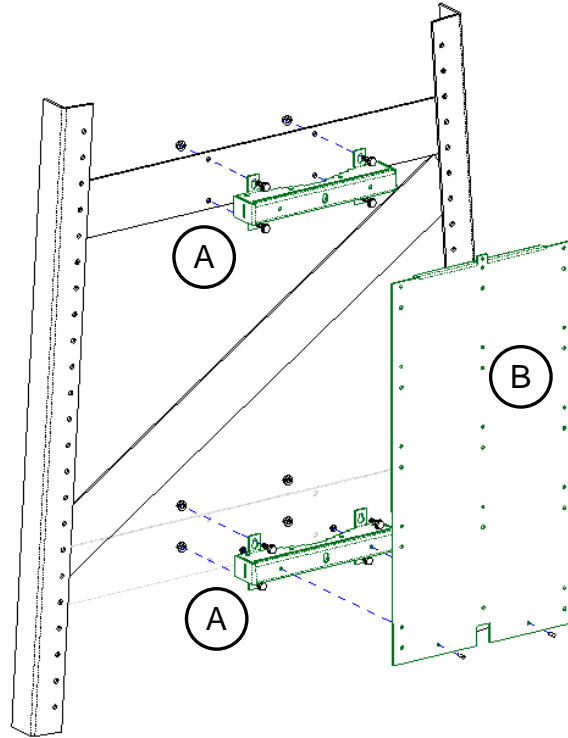

Figure 25- Pylon mounting example

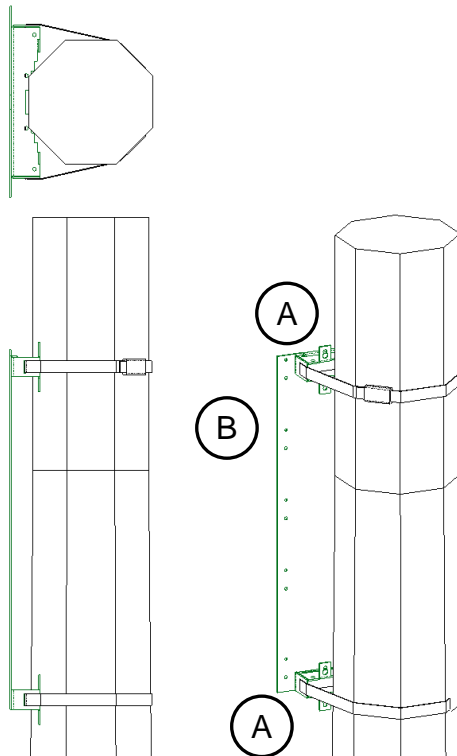



Figure 26 – Pole mounting example

	GLOBAL STANDARD	Page 36 of 36
	UP 2015 Box for outdoor installations	<b>GSTR001/3</b> Rev. 01

## 10 AMBIENT OPERATING CONDITIONS

The apparatus provided must be in compliance with the operating conditions listed below:

- Ambient temperature limit in the range of  $-10 \div 55$  °C;
- Atmospheric pressure in the range of  $70 \div 106$  kPa;
- Humidity limit of 93% at the max ambient temperature;
- Storage temperature in the range of  $-25 \div 70$  °C.

Besides, the cabinet container must have IP54 or higher degree of protection, and must be suitable to use in environmental conditions classified as **climatic category type C5-M "Very High"** (coastal areas with high salinity), as comprehensively described in in Chapter 5.1.2 - Environmental Conditions.

## 11 SUPPLY REQUIREMENTS

### 11.1 TCA documents and manuals

#### 11.1.1 TCA documents

The Enel technical organization unit in charge of the Technical Conformity Assessment of the device will supervise the technical documentation and the execution of the functional tests required to receive the "Statement of Conformity", according to GSCG002 prescriptions.

#### 11.1.2 Manuals

The supplier shall provide all the end-user documentation manuals of the UP and its components (e.g. operation, maintenance and installation manual, overall dimensional drawings, plate drawing, product colored pictures, etc). The information shall be provided on digital support.

All the manuals shall be in the local language of the device destination country.

#### 11.1.3 Safety warnings on Plate

The safety warnings required in the plate of the UP Box and its components must be written in the local language of the UP destination Country.

## 12 SAFETY REQUIREMENTS

Each component of the RTU, including the non-electrical ones, must be in compliance with all of the current safety regulations (where applicable).